

SOFT-STARTERS

Advanced technology for the soft-start of electric motors



Motors | Automation | Energy | Transmission & Distribution | Coatings

WEG

SSW900
T-STARTER

Pronta ~ Loc 0.0A 11:54
Corrente
S1.1.4 Média

0.0 A

LOC REM JOG

R / 1L1 S / 3L2 T / 5L3

A1 A2 D

MOTOR I

START

13 14/2

0 / 2T1 V / 4T2 W / 6T3

WEG
SSW 05
SOFT-STARTER Plus

WEG SSW 07
SOFT-STARTER

KICK START TIME: 2s, 0.2s, 1s

INITIAL VOLTAGE CURRENT LIMIT: 90% / 450%, 30% / 150%

ACCEL TIME: 40s

DECEL TIME: 40s

MOTOR CURRENT: 50%, 100%

THERMAL CLASS: 30, 20, 10, 5

FACTORY DEFAULT

ON KICK START: ON, OFF

OVERCURRENT, PHASE LOSS, PHASE SEQ, STALL, OVERLOAD

STATUS: FAULT, RUN, READY

LED FAULT	LED READY	FAULT DESCRIPTION
1x	OFF	FREQUENCY RANGE
1x	ON	OVERTEMPERATURE
2x	OFF	UNDERVOLTAGE
2x	ON	START TIMEOUT
3x	OFF	BY-PASS OPEN
4x	OFF	OVERCURRENT BEFORE BY-PASS
5x	OFF	BY-PASS OVERCURRENT

WEG SSW
SOFT-STARTER

KICK START TIME: 2s, 8.2s

INITIAL VOLTAGE CURRENT LIMIT: 90% / 450%, 30% / 150%

ACCEL TIME: 40s, 1s

DECEL TIME: 40s, OFF

MOTOR CURRENT: 50%, 100%

THERMAL CLASS: OFF, ON

FACTORY DEFAULT

LED FAULT	LED READY	FAULT DESCRIPTION
1x	OFF	FREQUENCY RANGE
1x	ON	OVERTEMPERATURE
2x	OFF	UNDERVOLTAGE
2x	ON	START TIMEOUT
3x	OFF	BY-PASS OPEN
4x	OFF	OVERCURRENT BEFORE BY-PASS
5x	OFF	BY-PASS OVERCURRENT

Soft-Starters

Summary

Introduction	04
Main Functions	06
Applications	07
Connectivity	08
SSW05	10
SSW07 / SSW08	12
SSW900	16
Comparison	21

ADVANCED TECHNOLOGY FOR THE SOFT-START OF ELECTRIC MOTORS



In view of the evolution of processes and machines, it has become increasingly clear the need to use resources that allow driving motors in a smooth and controlled way. Using cutting-edge technology, WEG soft-starters have been designed **to ensure the best performance for each kind of application**, offering resources that enable to start and stop three-phase induction motors in a simple and efficient way, protecting the motor and the load from torque shocks (jolts) by means of gradual acceleration up to the rated speed.

WEG soft-starters are **the ideal solutions with excellent cost-benefit** for starting and stopping three-phase induction motors in applications requiring speed and torque control during the start.



Benefits



Simple operation and maintenance



Easy installation and start-up



Effective motor protection



Free programming software



Special functions



Excellent cost-effectiveness

Main Functions

Kick Start

Ideal for applications where the loads require an extra effort from the drive at the moment of the start due to the high resistant torque, being necessary feed the motor with a higher voltage than that set in the acceleration voltage ramp.

Pump Control

This is a preset (specific) configuration for pumping systems, where it is usually necessary to establish a voltage ramp in the acceleration and deceleration, in addition to enabling protections in the SSW.

Motor Coasting

The SSW takes the output voltage instantaneously to zero, implying that the motor does not produce any torque on the load, which in turn will slow down until all the kinetic energy is dissipated.

Current Limitation

Used in most cases where the load has a high inertia, this function causes the grid/SSW system to feed the motor with the current just necessary to perform the load acceleration.

Reduction of the Water Hammer

Using an SSW to for stopping the motor softly (pump control) reduces the chances of Water Hammer.

Voltage Ramp in the Deceleration

At the controlled stop, the SSW will gradually reduce the output voltage to a minimum value in a preset time.

Voltage Ramp in the Acceleration

The SSW, by controlling the variation of the firing angle of the thyristor bridge generates a gradual and continuous effective voltage at its output, increasing until the rated line voltage is reached.

Note: for more details, refer to the catalog or user's manual of each SSW, available on our website: www.weg.net.



Applications

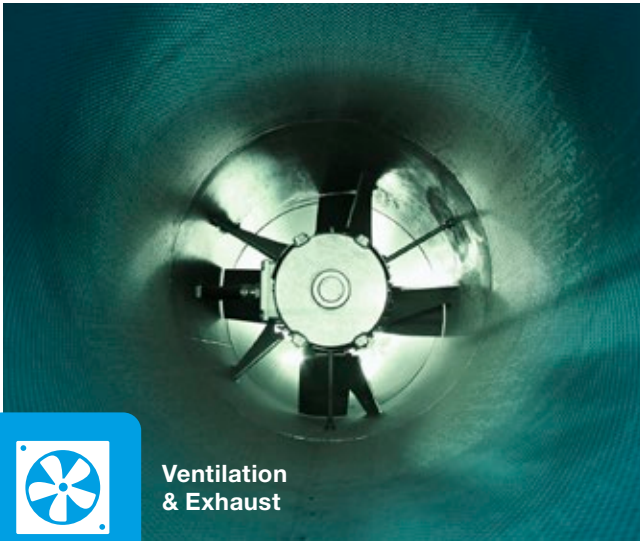

Ventilation
& Exhaust



Sugar &
Alcohol



Cement
& Mining



Agribusiness

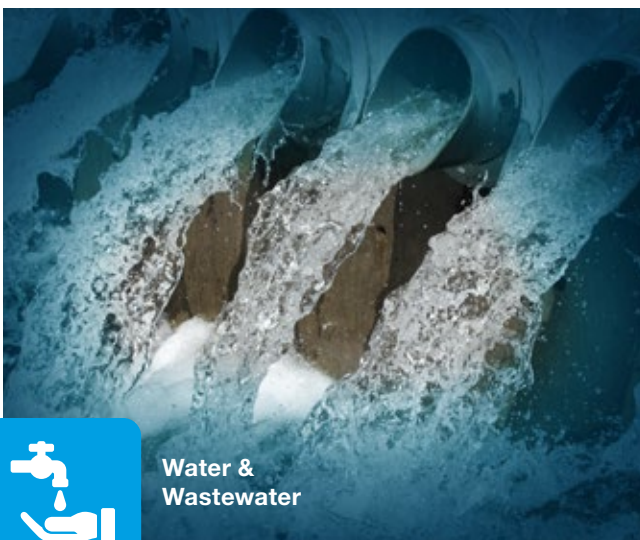

Water &
Wastewater



Chemical, Petrochemical,
Oil & Gas



Connectivity

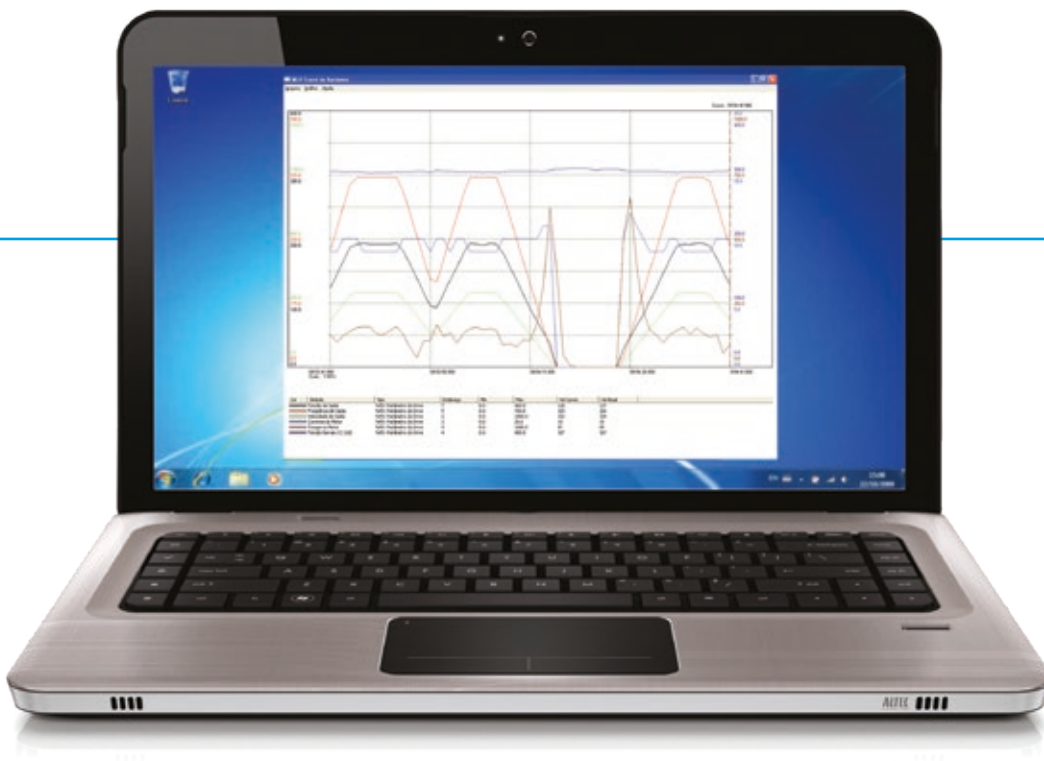

SuperDrive G2

Using the SuperDrive G2 software, it is possible to change, monitor and graphically view the variables of the frequency inverter via connection to a personal computer.

Trend Function

Trend charts for online monitoring of parameters and other variables within the SuperDrive G2 software.

- Easy operation and view
- Free on www.weg.net



WEG Programming Suite (WPS)

Integrated tool that assists in the creation of automation applications, allowing graphical monitoring, parameter setting and programming in Ladder language (IEC 61131-3) of various WEG product families.

- Multi-Products, meeting the requirements of a wide range of WEG products
- Multi-Use, allowing:
 - Parameter setting of the devices
 - Programming of the devices in Ladder language
 - Monitoring of the devices
 - Assistance in the creation and configuration of automation applications

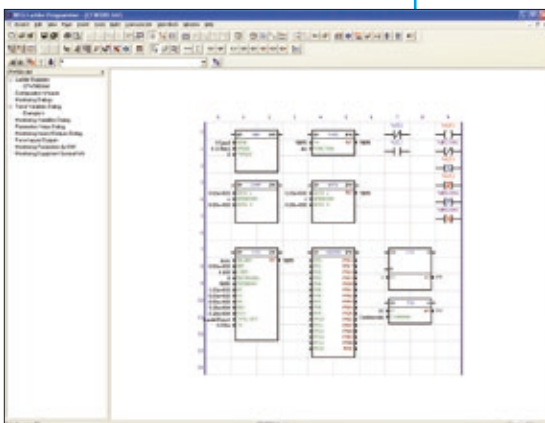
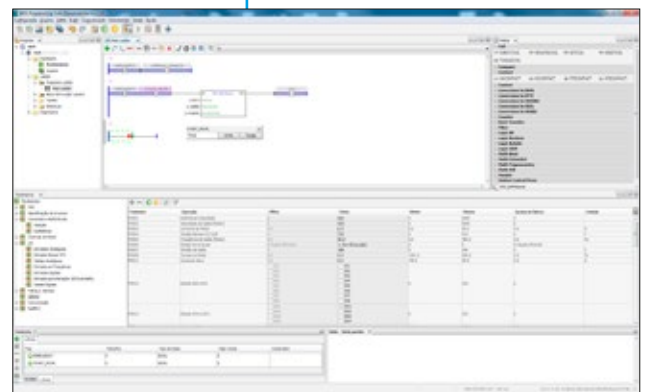

WEG Ladder Programmer (WLP)⁴⁾

Software for Windows[®] environment that enables the programming in Ladder language of various WEG product families.

- Edition of the program by means of several Ladder function blocks
- Compilation of the program in Ladder for a language compatible with the devices
- Transfer of the compiled program to the devices
- Reading of the program installed on the devices¹⁾
- Online monitoring of the program running on the devices
- Point-to-point communication with the devices through serial in RS232 or USB²⁾
- Serial communication in RS485 with up to 30 devices³⁾
- Online help with all the functions and blocks present in the software

Notes: 1) For devices that supports the upload function.

2) For devices that have a USB communication port.

3) Through an RS232-to-RS485 converter connected to the PC.

4) Functions valid only for SSW900.



SSW05

The SSW05 is WEG's most compact solid state starter with control of two motor phases, built-in bypass and all the protections for the electric motor. Featuring DSP control (Digital Signal Processor), the SSW05 is designed for optimal performance in motor start and stop, with excellent cost-effectiveness. In addition, they are easily set, simplifying the start-up activities and daily operations. Their compact dimensions contribute to the optimization of spaces in electrical panels.



Main Characteristics

- Current ranges from 3 to 85 A
- Supply voltage from 220 to 460 V ac or from 460 to 575 V ac
- Simple electrical installation
- Compact
- Control with digital processor (DSP)
- High efficiency
- Built-in bypass
- Electronic thermal relay
- Built-in motor protections
- Easy to operate, adjust and service
- Remote operating interface (HMI) (optional)
- Operation in environments up to 55 °C
- Great reduction of the forces on the couplings and on the transmission devices (gearboxes, pulleys, gears, belts, etc.) during the start
- Extended motor and equipment lifespan without mechanical shocks

Settings and Indications

Dip switch to enable/disable the motor protections

Protection LED indicators

Status LED indicators

Pedestal voltage, acceleration and deceleration time, and motor current settings

Three-phase power supply input

Electronics power supply and digital inputs

Connector for serial or remote HMI

Digital relay outputs

Certifications



Specifcation

The power ratings for the maximum applicable motor shown in the following tables are referential and valid for WEG 4-pole three-phase induction motors under light load conditions (e.g., centrifugal pump). Motor rated power may vary according to the motor data and application.

SSW05	Frame size	Rated current (A)	Maximum applicable motor							
			220/230 V		380/400 V		440/460 V		575 V	
			HP	kW	HP	kW	HP	kW	HP	kW
SSW050003T2246TPZ	1	3	0.75	0.5	1.5	1.1	2	1.5	-	-
SSW050010T2246TPZ		10	3	2.2	6	4.5	7.5	5.5	-	-
SSW050016T2246TPZ		16	5	3.7	10	7.5	12.5	9.2	-	-
SSW050023T2246TPZ		23	7.5	5.5	15	11	15	11	-	-
SSW050030T2246TPZ		30	10	7.5	20	15	20	15	-	-
SSW050045T2246TPZ	2	45	15	11	30	22	30	22	-	-
SSW050060T2246TPZ		60	20	15	40	30	40	30	-	-
SSW050085T2246TPZ		85	30	22	60	45	60	45	-	-
SSW050003T4657TPZ	1	3	-	-	-	-	-	-	2	1.5
SSW050010T4657TPZ		10	-	-	-	-	-	-	7.5	5.5
SSW050016T4657TPZ		16	-	-	-	-	-	-	10	7.5
SSW050023T4657TPZ		23	-	-	-	-	-	-	20	15
SSW050030T4657TPZ		30	-	-	-	-	-	-	25	18.9
SSW050045T4657TPZ	2	45	-	-	-	-	-	-	40	30
SSW050060T4657TPZ		60	-	-	-	-	-	-	50	37.8
SSW050085T4657TPZ		85	-	-	-	-	-	-	75	56.7

Accessories

Model	Description
SSW05-7-8-CB-RS-1M	1 m serial remote HMI cable
SSW05-7-8-CB-RS-2M	2 m serial remote HMI cable
SSW05-7-8-CB-RS-3M	3 m serial remote HMI cable
SSW05-HMI-RS	Remote HMI for use with CAB-RS cable up to 3 m

Dimensions and Weights

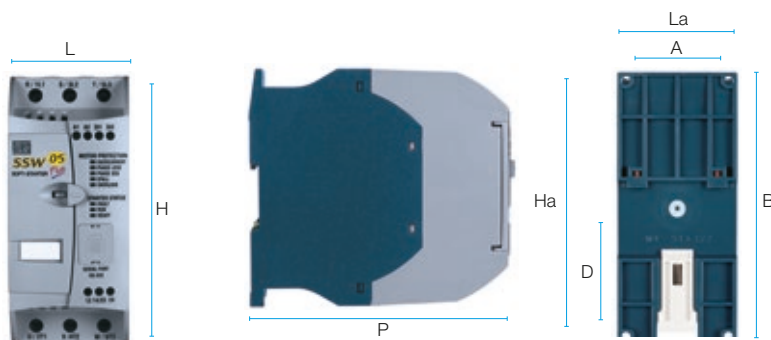

Size	Width L (mm)		Height H (mm)		Depth P (mm)	Mounting A (mm)	Mounting B (mm)	Mounting D (mm)	Mounting	Weight (kg)
	L	La	H	Ha						
1	59	60.4	130	130.7	145	51	122	61	M4 Screw/Rail	0.74
2	79	80.4	185	185.7	172	71	177	99	M4 Screw/Rail	1.64

Note: La, Ha, Mounting (only for mounting with screw).

SSW07 / SSW08



Developed for industrial or professional applications, the SSW07 and SSW08 soft-starters are compact and have built-in bypass, thus contributing to increased lifespan, space optimization and less heat dissipation in electrical panels.

The SSW07 and SSW08 soft-starters are equipped with the same functionalities. The SSW07 controls three motor phases, being recommended to drive heavy loads, while the SSW08 controls two motor phases, and it is recommended to drive light to moderate loads.

Main Characteristics

- Current ranges from 17 to 412 A
- Supply voltage from 220 to 575 V ac
- Simple electrical installation
- Built-in bypass
- Kick start function to start loads with high static friction
- Switched-mode power supply of the electronics with EMC filter (110 to 220 V)
- Full electronic motor protection
- Electronic thermal relay
- Thermal image (monitoring of the electronics voltage, allowing the backup of the current and voltage values)
- Interconnection with Fieldbus communication networks: Modbus-RTU and DeviceNet (optional)
- Human-Machine Interface - HMI (optional)
- Free SuperDrive G2 programming software

Certifications



Settings and Indications

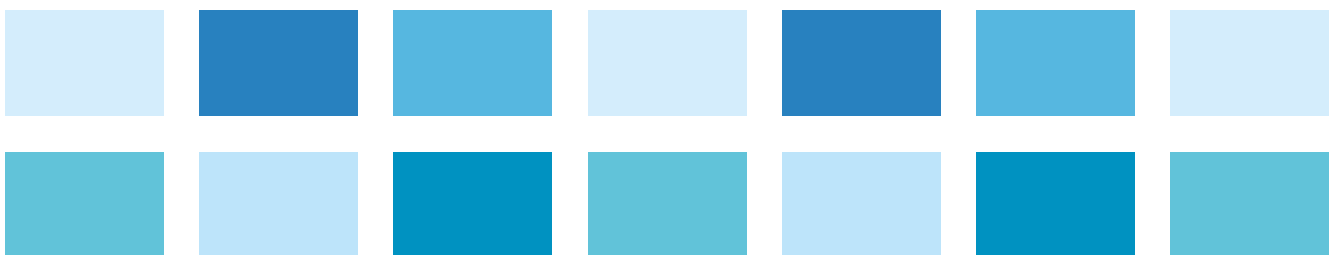
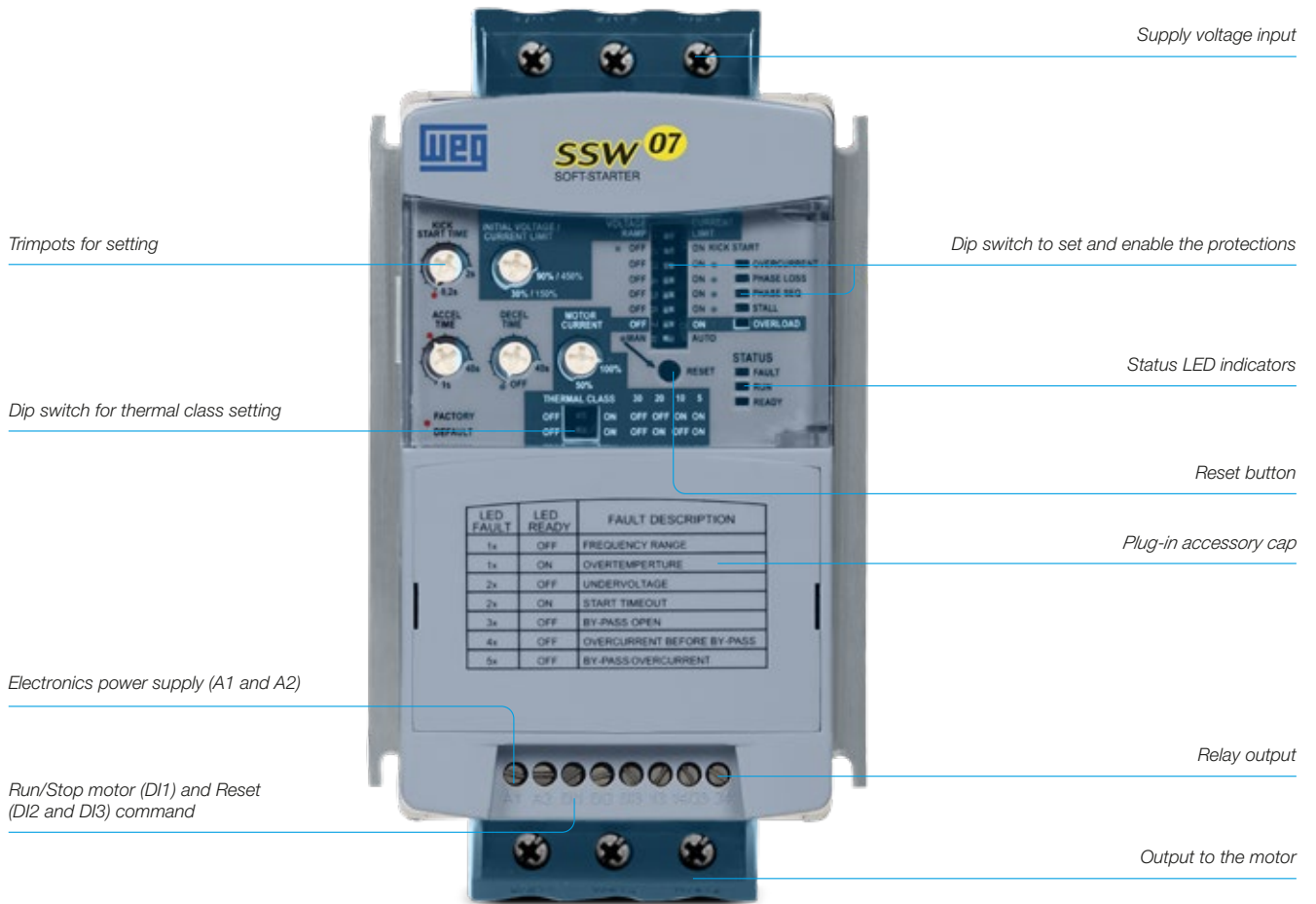

Specification

The power ratings for the maximum applicable motor shown in the following tables are referential and valid for WEG 4-pole three-phase induction motors under light load conditions (e.g., centrifugal pump). Motor rated power may vary according to the motor data and application.

SSW07/ SSW08	Frame size	Rated current (A)	Maximum applicable motor									
			220/230 V		380/400 V		440/460 V		525 V		575 V	
			HP	kW	HP	kW	HP	kW	HP	kW	HP	kW
SSW0□0017T5SZ	1	17	6	4.5	10	7.5	12.5	9.2	15	11	15	11
SSW0□0024T5SZ		24	7.5	5.5	15	11	15	11	20	15	20	15
SSW0□0030T5SZ		30	10	7.5	20	15	20	15	25	18.5	30	22
SSW0□0045T5SZ	2	45	15	11	30	22	30	22	40	30	40	30
SSW0□0061T5SZ		61	20	15	40	30	50	37	50	37	60	45
SSW0□0085T5SZ		85	30	22	60	40	60	45	75	55	75	55
SSW0□0130T5SZ	3	130	50	37	75	55	100	75	125	90	125	90
SSW0□0171T5SZ		171	60	45	125	90	125	90	150	110	175	132
SSW0□0200T5SZ		200	75	55	125	90	150	110	200	150	200	150
SSW0□0255T5SH♦Z	4	255	100	75	175	130	200	150	250	185	250	185
SSW0□0312T5SH♦Z		312	125	90	200	150	250	185	300	220	300	220
SSW0□0365T5SH♦Z		365	150	110	250	185	300	220	350	260	350	260
SSW0□0412T5SH♦Z		412	150	110	300	220	350	260	440	315	450	330

Notes: Replace □ to the desired option, 7 for SSW07 or 8 for SSW08.

Replace ♦ by 1 for 110 V control voltage power supply or 2 for 220 V control voltage power supply.

WEG Premium motors or Plus / IV Poles - 60 Hz.

Accessories

Reference	Description
SSW07-08-HMI-LOC	Local Human-Machine Interface - HMI
SSW07-HMI-REM	Remote human-machine interface kit (HMI LED + HMI interface module) for SSW07
SSW08-HMI-REM	Remote human-machine interface kit (HMI LED + HMI interface module) for SSW08
CAB-RS-1M-SSW07/08	1 m cable to connect to remote HMI
CAB-RS-2M-SSW07/08	2 m cable to connect to remote HMI
CAB-RS-3M-SSW07/08	3 m cable to connect to remote HMI
CAB-RS-5M-SSW07/08	5 m cable to connect to remote HMI
CAB-RS-7,5M-SSW07/08	7.5 m cable to connect to remote HMI
CAB-RS-10M-SSW07/08	10 m cable to connect to remote HMI
HMI-SSW07-REM+RS485	Remote human-machine interface kit (HMI LED + HMI interface module) for SSW07
HMI-SSW08-REM+RS485	Remote human-machine interface kit (HMI LED + HMI interface module) for SSW08
SSW07-08-KRS-485	RS485 communication kit
KFB-DN-SSW07/08	DeviceNet communication module
SSW07-08-KRS-232	RS232 communication module
KRS232-SSW07/08	RS232 communication module and cable kit
CAB-SER-3M-SSW07/08	3 m cable for serial connection to PC
CAB-SER-10M-SSW07/08	10 m cable for serial connection to PC
SSW0708900-KVT-2B	Ventilation kit for frame 2 (currents from 45 to 85 A)
SSW0708900-KVT-3C	Ventilation kit for frame 3 (currents from 130 to 200 A)
SSW07-08-KPTC-MTR	Motor PTC module
SSW07/08/900-IP20-3C	IP20 kit for frame 3 (currents from 130 to 200 A)
SSW07/08/900-IP20-4D	IP20 kit for frame 4 (currents from 255 to 412 A)
SSW0708900-PROT-3C	Touch protection kit for frame 3 (currents from 130 to 200 A)
SSW0708900-PROT-4D	Touch protection kit for frame 4 (currents from 130 to 200 A)

Dimensions and Weights

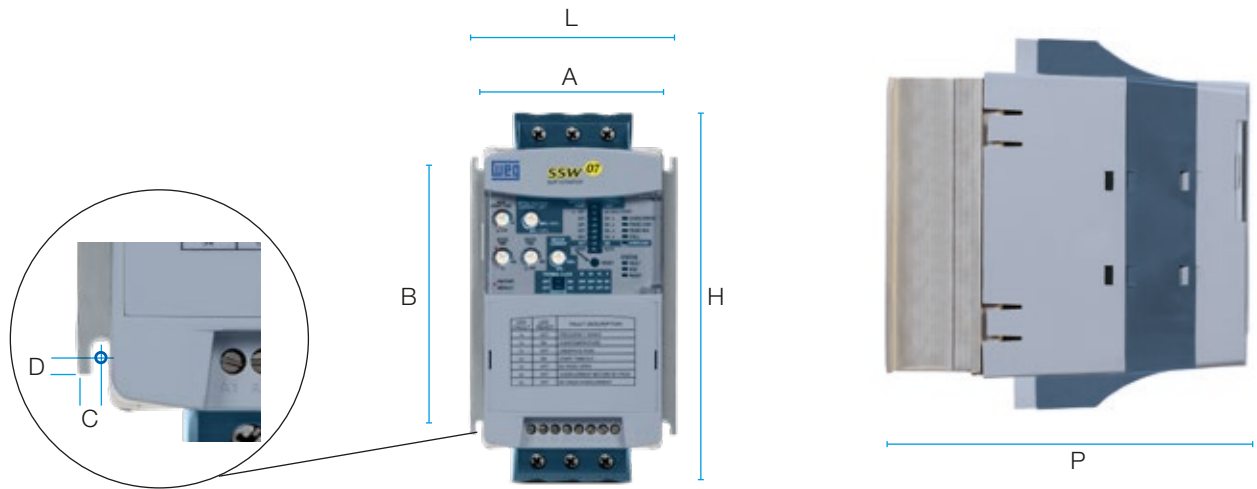

The SSW07 and SSW08 soft-starters have the same dimensions, according to following table:

Model	Height H (mm)	Width L (mm)	Depth P (mm)	A (mm)	B (mm)	C (mm)	D (mm)	Mounting screw	Weight (kg)	Protection rating
17 A 24 A 30 A	162	95	157	85	120	5	4	M4	1.3	IP20
45 A 61 A 85 A	208	144	203	132	148	6	3.4	M4	3.3	IP20
130 A 171 A 200 A	276	223	220	208	210	7.5	5	M5	7.6	IP00 ¹⁾
255 A 312 A 365 A 412 A	331	227	242	200	280	15	9	M8	11.5	IP00 ¹⁾

Note: 1) IP20 with accessory kit KIP20.

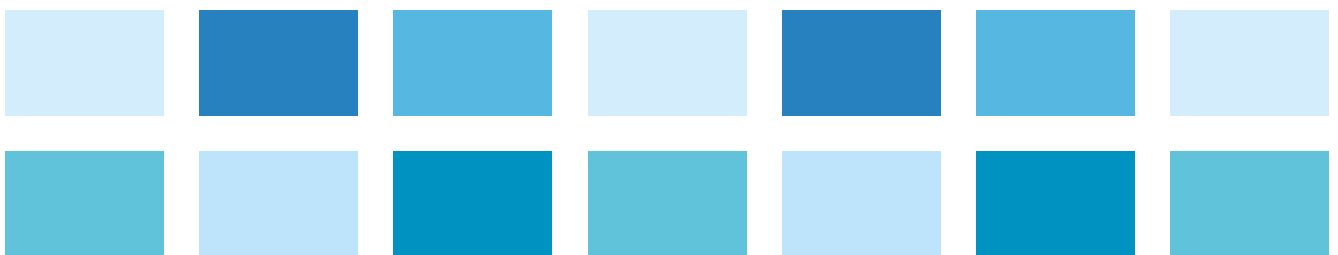

SSW900



Combining convenience and innovation, the SSW900 is the right choice for the full motor start, stop and protection control. Developed for industrial or professional use, the new line of soft-starters allows simple and quick access to information on the application and configuration settings.

Using a menu structure, the new interface of the SSW900 line presents an unprecedented experience of interactivity with the user, allowing settings and configurations with online parameter help right on the HMI, in addition to event logs with date and time and setup wizard.

The equipment also has built-in bypass, which contributes to extending the lifespan of the drive, optimizing space and reducing heat dissipation in electric panels.

Main Characteristics

- Current ranges from 10 to 1,400 A
- Supply voltage from 220 to 575 V ac (T5) or from 380 to 690 V ac (T6)
- Oriented start-up
- Standard connection (3 cables) or motor inside delta connection (6 cables)
- Integral motor thermal protection
- Reduction of voltage drops during motor start
- Pump control function for smart control of pumping systems that prevent water hammer and pressure overshoots in the hydraulic piping
- Great mechanical stresses reduction on the couplings and transmission devices (gear boxes, pulleys, gears, belts, etc.) during the motor start
- Increased motor and equipment lifetime
- Elimination of starting mechanical shock to couplings and driven equipment
- Operation at ambient temperature up to 55 °C without current¹⁾ derating
- Three braking methods to stop the motor and the load faster. Braking methods with or without external contactors
- Built-in bypass: minimizing power losses and heat dissipation in the thyristor, providing space reduction, contributing to energy saving and increasing the product's life

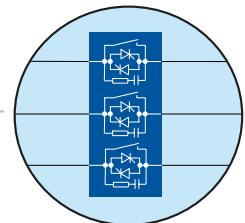

MORE + ADVANTAGES

The SSW900 can substitute direct online starters or star-delta starters, bringing benefits to your application, such as:

- Electric energy savings
- Greater protection and increased durability of the electric motor
- Diagnosis and fault history
- Flexibility, it allows the installation of accessories in the application (plug and play)
- Graphic monitoring
- Customizable main screens



Menu navigation



Easy to install



Easy to operate



Simple monitoring

Note: 1) Models A to D.

Easy to Use

USB Port

Easy monitoring via PC or firmware updating

Detachable Keypad

Option to install on machine or panel door

Easy access to the control terminals: digital and analog inputs and outputs



Bluetooth connectivity¹⁾

RTC

Real time clock with event log including date and time

Graphic HMI

Intuitive, customizable, complete

Flexibility

LED

Visual status indication

Two Slots

Two accessory modules can be used

RTC battery

Quick Connect

Detachable terminals

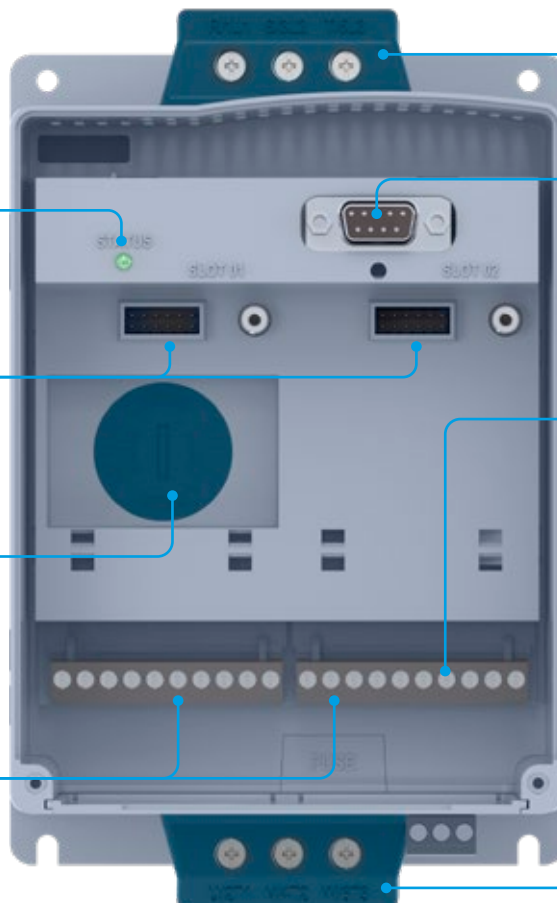

Power supply connection

HMI connection

I/O

Totally programmable inputs and outputs

- **5 isolated digital** input 24 V dc
- **1 analog output** 0-10 V dc / 4-20 mA
- **1 input** for the motor PTC
- **3 relay outputs** 1.0 A / 240 V ac

Motor connection

Note: 1) HMI with Bluetooth connectivity available as an accessory item. Please consult the availability for your region.

Specification

The power ratings for the maximum applicable motor shown in the following tables are referential and valid for WEG 4-pole three-phase induction motors under light load conditions (e.g., centrifugal pump). Motor rated power may vary according to the motor data and application.

Standard Connection (with 3 Cables)

SSW900	Frame size	Rated current (A)	Maximum applicable motor											
			220/230 V ¹⁾		380/400 V		440/460 V		525 V		575 V		690 V ²⁾	
			HP	kW	HP	kW	HP	kW	HP	kW	HP	kW	HP	kW
SSW900A0010T5E2	A	10	3	2.2	6	4.5	7.5	5.5	7.5	5.5	10	7.5	-	-
SSW900A0017T5E2		17	6	4.5	10	7.5	12.5	9.2	15	11	15	11	-	-
SSW900A0024T5E2		24	7.5	5.5	15	11	15	11	20	15	20	15	-	-
SSW900A0030T5E2		30	10	7.5	20	15	20	15	25	18.5	30	22	-	-
SSW900B0045T5E2	B	45	15	11	30	22	30	22	40	30	40	30	-	-
SSW900B0061T5E2		61	20	15	40	30	50	37	50	37	60	45	-	-
SSW900B0085T5E2		85	30	22	60	45	60	45	75	55	75	55	-	-
SSW900B0105T5E2		105	40	30	75	55	75	55	75	55	100	75	-	-
SSW900C0130□E2	C	130	50	37	75	55	100	75	125	90	125	90	150	110
SSW900C0171□E2		171	60	45	125	90	125	90	150	110	175	132	220	165
SSW900C0200□E2		200	75	55	150	110	150	110	200	150	200	150	250	185
SSW900D0255□E♦	D	255	100	75	175	132	200	150	250	185	250	185	340	250
SSW900D0312□E♦		312	125	90	200	150	250	185	300	220	300	220	430	320
SSW900D0365□E♦		365	150	110	250	185	300	225	350	260	400	300	470	350
SSW900D0412□E♦		412	150	110	300	220	350	260	440	315	450	330	500	370
SSW900E0480□E♦	E	480	200	150	350	260	400	300	500	370	500	370	600	450
SSW900E0604□E♦		604	250	185	450	330	500	370	600	450	650	485	750	550
SSW900E0670□E♦		670	250	185	500	370	550	410	650	485	750	550	850	630
SSW900F0820□E♦	F	820	350	260	550	410	700	525	800	600	850	630	1,000	750
SSW900F0950□E♦		950	400	300	750	550	800	600	900	670	1,050	775	1,150	860
SSW900G1100□E♦	G	1,100	450	330	800	600	900	670	1,100	810	1,200	900	1,300	1,000
SSW900G1400□E♦		1,400	550	410	1,000	750	1,200	900	1,400	1,050	1,500	1,100	1,700	1,250

Notes: 1) Only for T5 versions.

2) Only for T6 versions.

Change □ by T5 for products with 220-575 V supply voltage or T6 for 380-690 V.

Change ♦ by 3 to select the control voltage of 110-130 V or by 4 to 220-240 V.

Models ≤412 A: AC-53b 3-25:335, ambient temperature of 55 °C.

Models ≥480 A: AC-53b 3-25:695, ambient temperature of 40 °C.

Models from 130 A to 200 A: with ventilation kit.

WEG motors Premium or Plus, IV poles.

Motor Inside Delta Connection (with 6 Cables)

SSW900	Frame size	Rated current (A)	Maximum applicable motor									
			220/230 V ¹⁾		380/400 V		440/460 V		525 V ²⁾		575 V ²⁾	
			HP	kW	HP	kW	HP	kW	HP	kW	HP	kW
SSW900C0130T5E2	C	225	75	55	150	110	175	132	200	150	250	185
SSW900C0171T5E2		296	125	90	200	150	200	150	250	185	300	220
SSW900C0200T5E2		346	150	110	250	185	300	220	300	220	350	260
SSW900D0255T5E♦	D	441	175	132	300	220	350	260	400	300	450	330
SSW900D0312T5E♦		540	200	150	350	260	450	330	500	370	550	410
SSW900D0365T5E♦		631	250	185	450	330	500	370	600	450	650	485
SSW900D0412T5E♦		713	250	185	500	370	600	450	700	525	800	600
SSW900E0480T5E♦	E	831	350	260	600	450	700	525	800	600	900	670
SSW900E0604T5E♦		1,046	450	330	750	550	850	630	1,050	775	1,150	820
SSW900E0670T5E♦		1,160	500	370	850	630	950	700	1,150	820	1,250	920
SSW900F0820T5E♦	F	1,420	600	450	1,000	750	1,200	900	1,400	1,050	1,550	1,140
SSW900F0950T5E♦		1,645	720	520	1,200	900	1,400	1,030	1,650	1,200	1,800	1,325
SSW900G1100T5E♦	G	1,905	800	600	1,400	1,030	1,600	1,175	1,900	1,400	2,100	1,550
SSW900G1400T5E♦		2,425	1,050	775	1,750	1,290	2,000	1,475	2,450	1,800	2,650	1,950

Notes: 1) Only for T5 versions.

2) Only for T6 versions.

Change ♦ by 3 to select the control voltage of 110-130 V or by 4 to 220-240 V.



Models ≤412 A: AC-53b 3-25:335, ambient temperature of 55 °C.

Models ≥480 A: AC-53b 3-25:695, ambient temperature of 40 °C.

Models from 130 A to 200 A: with ventilation kit.

WEG motors Premium or Plus, IV poles.

Accessories

Accessory	Description	Image
Accessories for communication and control - Slots 1 and 2		
SSW900-CAN-W	CANopen and DeviceNet communication plug-in module	
SSW900-CRS485-W	Modbus-RTU communication plug-in module	
SSW900-CDN-N	DeviceNet - Anybus communication plug-in module	
SSW900-CPDP-N	Profibus-DP - Anybus communication plug-in module	
SSW900-CETH-IP-N	EtherNet/IP - Anybus communication plug-in module	
SSW900-CMB-TCP-N	Modbus-TCP - Anybus communication plug-in module	
SSW900-CPN-IO-N	PROFINET IO - Anybus communication plug-in module	
SSW900-CETH-W ¹⁾	Ethernet/IP communication plug-in module	
SSW900-HMI-BLT	Remote operating interface with Bluetooth communication	
SSW900-PT100-W	Temperature plug-in module for PT100 sensors - 6 channels	
Accessories for mechanical installation		
SSW0708900-KVT-2B	Ventilation kit for frame B (currents from 45 to 105 A)	
SSW0708900-KVT-3C	Ventilation kit for frame C (currents from 130 to 200 A)	
SSW0708900-IP20-3C	IP20 kit for frame C (currents from 130 to 200 A)	
SSW0708900-IP20-4D	IP20 kit for frame D (currents from 255 to 412 A)	
SSW0708900-PROT-3C	Front cover kit for power terminals of frame C (currents from 130 to 200 A)	
SSW0708900-PROT-4D	Front cover kit for power terminals of frame D (currents from 255 to 412 A)	
SSW900-PROT-E	Front cover kit for power terminals of frame E (currents from 480 to 670 A)	
Other accessories		
SSW900-KMD-CB01	Frame kit for HMI + 1 m cable	-
SSW900-KMD-CB02	Frame kit for HMI + 2 m cable	-
SSW900-KMD-CB03	Frame kit for HMI + 3 m cable	-
SSW900-KMD-CB05	Frame kit for HMI + 5 m cable	-
SSW900-KMD-CB07	Frame kit for HMI + 7,5 m cable	-
SSW900-KMD-CB10	Frame kit for HMI + 10 m cable	-
SSW900-KMD-CB20	Frame kit for HMI + 20 m cable	-
SSW900-KECA-10	Current acquisition kit for 10 A	-
SSW900-KECA-17	Current acquisition kit for 17 A	-
SSW900-KECA-24	Current acquisition kit for 24 A	-
SSW900-KECA-30	Current acquisition kit for 30 A	-
SSW900-KECA-45	Current acquisition kit for 45 A	-
SSW900-KECA-61	Current acquisition kit for 61 A	-
SSW900-KECA-85	Current acquisition kit for 85 A	-
SSW900-KECA-105	Current acquisition kit for 105 A	-
SSW900-KECA-130	Current acquisition kit for 130 A	-
SSW900-KECA-171	Current acquisition kit for 171 A	-
SSW900-KECA-200	Current acquisition kit for 200 A	-
SSW900-KECA-255	Current acquisition kit for 255 A	-
SSW900-KECA-312	Current acquisition kit for 312 A	-
SSW900-KECA-365	Current acquisition kit for 365 A	-
SSW900-KECA-412	Current acquisition kit for 412 A	-
SSW900-6BAR-E	Kit with six bars for frame E (currents from 480 to 670 A)	-
SSW900-6BAR-F	Kit with six busbars for frame F (currents of 820 and 950 A)	-
SSW900-3BAR-G	Kit with three busbars for frame G (currents of 1,100 and 1,400 A)	-

Note: 1) Please check availability with your sales representative.

Accessory Installation

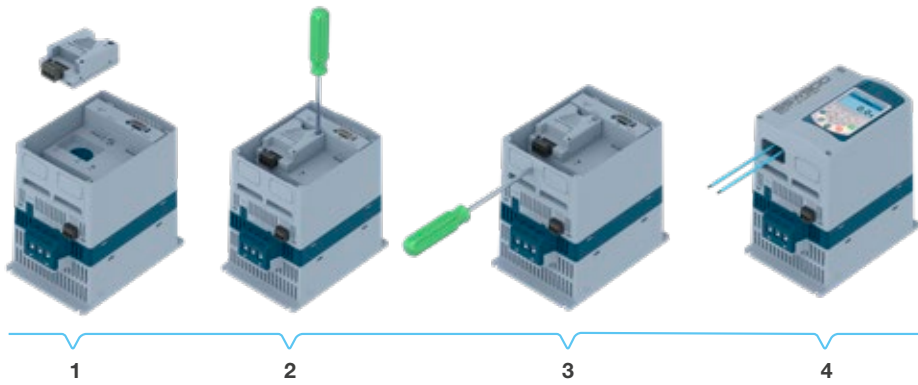

Dimensions

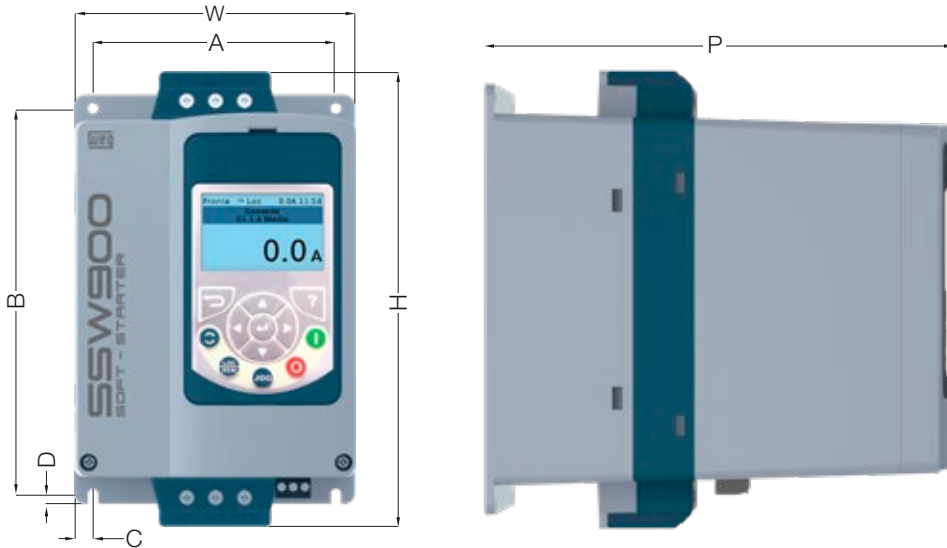

Frame size	Height (H) mm (in)	Width (W) mm (in)	Depth (P) mm (in)	(A) mm (in)	(B) mm (in)	(C) mm (in)	(D) mm (in)	Fastening screw	Weight (kg) (lb)	Degree of protection
A	200 (7.87)	127 (5)	203 (7.99)	110 (7.33)	175 (6.88)	8.5 (0.33)	4.3 (0.16)	M4	1.93 (4.25)	IP20
B	208 (8.18)	144 (5.66)	260 (10.23)	132 (5.19)	148 (5.82)	6 (0.23)	3.4 (0.13)	M4	4.02 (8.86)	IP20
C	276 (10.86)	223 (8.77)	261 (10.27)	208 (8.18)	210 (8.26)	7.5 (0.29)	5 (0.19)	M5	6.55 (14.44)	IP00 ¹⁾
D	331 (13.03)	227 (8.93)	282 (11.10)	200 (7.87)	280 (11.02)	15 (0.59)	9 (0.35)	M8	12.83 (28.28)	IP00 ¹⁾
E	575 (22.63)	390 (15.35)	260 (10.23)	270 (10.62)	480 (18.89)	56 (2.20)	10 (0.40)	M8	38 (83.75)	IP00
F	760 (29.92)	464 (18.27)	316 (12.44)	320 (12.60)	625 (24.61)	72 (2.83)	10 (0.39)	M8	75.40 (166.23)	IP00
G	914 (35.98)	539 (21.22)	316 (12.44)	369 (14.53)	732 (28.82)	85 (3.35)	12 (0.47)	M10	107.20 (236.34)	IP00

Note: IP20 with optional kit.

Comparison

Comparison		SSW05	SSW07	SSW08	SSW900
Current range		3 - 85 A	17 - 412 A	17 - 412 A	10 - 1,400 A
Power supply	Power voltage	220 - 460 V ac (+10%, -15%) 460 - 575 V ac (+10%, -15%)	220 - 575 V ac (+10%, -15%)	220 - 575 V ac (+10%, -15%)	220 - 575 V ac (+10%, -15%) 380 - 690 V ac (+10%, -15%)
	Frequency	50 / 60 Hz	50 / 60 Hz (±10%)	50 / 60 Hz (±10%)	50 / 60 Hz (±10%)
	Control voltage	90 - 250 V ac	110 - 240 V ac (+10%, -15%)	110 - 240 V ac (+10%, -15%)	110 - 240 V ac (+10%, -15%)
Protection rating		IP00	IP20 up to 85 A IP00 above 85 A (optional IP20 kit)	IP20 up to 85 A IP00 above 85 A (optional IP20 kit)	IP20 up to 85 A IP00 above 85 A (optional IP20 kit for frames C and D)
Overload duty	Normal	300% for 10s, 4 starts per hour	300% for 30s, 10 starts per hour (frames A and D standard or frames B and C with ventilation kit)	300% for 20s, 10 starts per hour (frames A and D standard or frames B and C with ventilation kit)	Up to 412 A: 300% for 30s, 10 starts per hour (frames A and D standard or B and C with ventilation kit) Above 480 A: 300% for 30s, 5 starts per hour.
Controlled phases		2 phases	3 phases	2 phases	3 phases
Built-in bypass		Yes	Yes	Yes	Yes
Inside delta connection		No	No	No	Yes, above 105 A
Initial voltage		30 - 80%	30 - 90%	30 - 90%	25 - 90%
Starting time		Yes, 1 to 20s	Yes, 1 to 999s	Yes, 1 to 999s	Yes, 1 to 999s
Stoppage time		Yes, 1 to 20s	Yes, 1 to 240s	Yes, 1 to 240s	Yes, 1 to 999s
Braking methods	Reverse braking	No	No	No	Yes (requires two external contactors)
	DC braking	No	No	No	Yes
	Optimal braking	No	No	No	Yes
Control types	Voltage ramp	Yes	Yes	Yes	Yes
	Current ramp	No	No	No	Yes
	Current limit	No	Yes	Yes	Yes
	Kick-start	No	Yes	Yes	Yes
	Torque control	No	No	No	Yes
	Pump control	No	No	No	Yes
Inputs	Digital	2 (110 - 230 V ac), one of those is programmable	3 (110 - 240 V ac) programmable	3 (110 - 240 V ac) programmable	5 (24 V dc) programmable
	PTC input	No	Yes (optional kit)	Yes (optional kit)	Yes (standard)
Outputs	Relay	1 relay output with NO contact, 250 V ac, 1 A, programmable	2 relay outputs with NO contact, 240 V ac, 1 A, programmable	2 relay outputs with NO contact, 240 V ac, 1 A, programmable	2 relay outputs with NO contact and 1 with NO/NC contact, 240 V ac, 1 A, programmable
	Analog	No	No	No	1 programmable (1 x 0-10 V dc or 1 x 4-20 mA)
Interfaces		RS232C ¹⁾	CAN ²⁾ , RS232 ²⁾ or RS485 ²⁾	CAN ²⁾ , RS232 ²⁾ or RS485 ²⁾	USB ³⁾ , CAN ²⁾ , Ethernet ²⁾ , RS485 ²⁾ or Bluetooth ²⁾
Fieldbus Protocols		Modbus-RTU	Modbus-RTU and DeviceNet	Modbus-RTU and DeviceNet	DeviceNet, Profibus DP, Profibus DP-V1, EtherNet/IP, Modbus-TCP, PROFINET IO, CANopen and Modbus-RTU
HMI		Optional, remote LED display	Optional, local or remote LED display	Optional, local or remote LED display	Built-in detachable local HMI with graphic LCD display. HMI with Bluetooth connectivity available as an accessory item.

Notes: 1) Built-in interface for connection with external HMI or with RS485 network (using MIW02 accessory).

2) Available with an accessory.

3) Available as standard.

Comparison

Comparison		SSW05	SSW07	SSW08	SSW900
Protections	Phase loss	Phase loss	Phase loss in the power supply and in the motor	Phase loss in the power supply and in the motor	Phase loss in the power supply and in the motor
	Locked rotor	Locked rotor	Locked rotor	Locked rotor	Locked rotor
	Motor overload	Motor overload	Motor overload	Motor overload	Motor overload
	Overcurrent	Over and undercurrent in the motor	Over and undercurrent in the motor	Over and undercurrent in the motor	Over and undercurrent in the motor
	-	Overtemperature in the motor and in the soft-starter	Overtemperature in the motor and in the soft-starter	Overtemperature in the motor and in the soft-starter	Overtemperature in the motor and in the soft-starter
	-	Fault in the thyristor (overheating)	Fault in the thyristor (overheating)	Fault in the thyristor (overheating)	Fault in the thyristor
	Phase sequence	Phase sequence	Phase sequence	Phase sequence	Phase sequence
	-	Undervoltage in the electronics	Undervoltage in the electronics	Undervoltage in the electronics	Undervoltage in the electronics
	-	Fault in the bypass	Fault in the bypass	Fault in the bypass	Fault in the bypass
	-	Overcurrent before the bypass closes	Overcurrent before the bypass closes	Overcurrent before the bypass closes	Under and overcurrent before the bypass closes
	-	Supply line frequency out of the range	Supply line frequency out of the range	Supply line frequency out of the range	Supply line frequency out of the range
	-	Voltage and current imbalance	Voltage and current imbalance	Voltage and current imbalance	Voltage and current imbalance
	Internal fault	Internal fault	Internal fault	Internal fault	Internal fault
	-	-	-	-	Warning for alarms before going into fault
	-	-	-	-	Under and overvoltage in the power
	-	-	-	-	Ground fault
	-	-	-	-	Motor not connected
	-	-	-	-	Motor wrong connection
	-	-	-	-	Under and overtorque
	-	-	-	-	Over and underpower
-	-	-	-	Starting time exceeded	
Ambient conditions	Temperature	0 - 55 °C without derating	0 - 55 °C without derating	0 - 55 °C without derating	0 - 55 °C without derating (frames A to D) 0 - 40 °C without derating (frames E, F and G)
	Humidity	0...90% non-condensing	5...90% non-condensing	5...90% non-condensing	5...90% non-condensing
	Altitude	Up to 1,000 m without derating 1,000 - 4,000 m with 1% derating every 100 m	Up to 1,000 m without derating 1,000 - 4,000 m with 1% derating every 100 m	Up to 1,000 m without derating 1,000 - 4,000 m with 1% derating every 100 m	Up to 1,000 m without derating 1,000 - 4,000 m with 1% derating every 100 m
Other resources	Communication with PC	Yes	Yes	Yes	Yes
	SoftPLC function	No	No	No	Yes

Global presence is essential,
as much as understanding your needs.

Global Presence

With more than 30,000 employees worldwide, WEG is one of the largest electric motors, electronic equipments and systems manufacturers. We are constantly expanding our portfolio of products and services with expertise and market knowledge. We create integrated and customized solutions ranging from innovative products to complete after-sales service.

WEG's know-how guarantees the **line of Soft-Starters** is the right choice for your application and business, assuring safety, efficiency and reliability.



Availability is to have a global support network



Partnership is to create solutions that suit your needs



Competitive edge is to unite technology and innovation

Know More

High performance and reliable products to improve your production process.

Excellence is to provide a whole solution in industrial automation that improves our customers productivity.



Visit:

www.weg.net



youtube.com/wegvideos

For WEG's worldwide
operations visit our website



www.weg.net



AUTOMATION

 +55 47 3276.4000

 automacao@weg.net

 Jaraguá do Sul - SC - Brazil

Cod: 50019077 | Rev: 14 | Date (m/a): 05/2021.

The values shown are subject to change without prior notice.

The information contained is reference values.